



SIDE-POWER Thruster Systems

EN Installation & User Manual Radio Remote rev1.0.3

RC-20E



RC-21E



RC-22E



RC-23E



SLEIPNER MOTOR AS

P.O. Box 519
N-1612 Fredrikstad
Norway
Tel: +47 69 30 00 60
Fax: +47 69 30 00 70



www.side-power.com
sidepower@sleipner.no

Made in Norway

Contents

Model range.....	2
Technical specifications.....	3
Important precautions.....	3
Receiver installation.....	4
User precautions.....	6
How to use RC20E.....	7
How to use RC21E.....	8
How to use RC22E.....	9
How to use RC23E.....	10
Transmitter LED operation and alarm indication.....	12
Electric diagram.....	13
Output signals diagram.....	14
Programming additional transmitters.....	15
Replacing transmitter battery.....	16
Dimensions.....	17

Model range

The radio remote control can control a single bow thruster/windlass or a bow and stern thruster/windlass combined. The receiver can receive the signals of up to four transmitters.

Remote control kit RC-20E consists of:

- Receiver: Part no. RCR-2E
- Transmitter (incl. battery): Part no. RCT-20E
- Holding bracket for transmitter unit: Part no. RC-HOLDER

Remote control kit RC-21E consists of:

- Receiver: Part no. RCR-2E
- Transmitter (incl. battery): Part no. RCT-21E
- Holding bracket for transmitter unit: Part no. RC-HOLDER

Remote control kit RC-22E consists of:

- Receiver: Part no. RCR-2E
- Transmitter (incl. battery): Part no. RCT-22E
- Holding bracket for transmitter unit: Part no. RC-HOLDER

Remote control kit RC-23E consists of:

- Receiver: Part no. RCR-2E
- Transmitter (incl. battery): Part no. RCT-23E
- Holding bracket for transmitter unit: Part no. RC-HOLDER

Additional transmitters can be ordered separately;

The transmitter and the receiver have the same factory preset code so no programming is necessary. The battery is already inserted in the transmitter.

When additional transmitters are to be used, the new transmitter(s) must be paired with the receiver (please see programming section).



We **Sleipner Motor AS** declare that this device complies with health and safety requirements according to the Directives
EN301 489-3 V1.4.1:2002
EN301 489-1 V1.4.1:2008
IEC 60533:1999
EN300 220-1 V2.3.1:2010
EN300 220-2 V2.3.1:2010



Technical specifications



	Transmitter	Receiver
Power feed	1x3V battery (type: CR2032)	12V or 24V power source
Frequency (MHz)	868MHz	868MHz
RF-power	<10mW	<10mW
Operation temp.	-10°C / +55°C	-15°C / +55°C
HxWxD (mm)	107x47x21	83x136x36
Weight (g)	60	275
Voltage		8-30V
Load, max		4A
Operating range	15m under normal operating conditions	

Important precautions

- With the boat on land, only run the thruster for a fraction of a second, as without resistance it will accelerate very fast to a damaging rpm.
- This manual is intended to support educated / experienced staff.
- When installed in boats approved or classified according to international or special national rules, the installer is responsible for following the demands in accordance with these regulations / classification rules. The instructions in this guide can not be guaranteed to comply with all different regulations / classification rules.
- The transmitter and the receiver have the same factory preset code so no programming is necessary. When additional transmitters are to be used, follow the instructions in the programming section on page 15.



Receiver installation

Prior to installation, it is important that the responsible installer reads this guide to ensure necessary acquaintance with this product.

WARNING!

Remote receiver power supply negative lead must be connected to the thrusters's negative lead. Power to the thruster's must be switched off during installation!

- Install the receiver minimum 1 meter (3ft) from high power cables and data communication cables or other sources of electrical interference, i.e. navigation instruments, radio communication devices, electric motors and generators.
- Install the receiver minimum 1 meter (3ft) above sea level.
- Install the receiver outside of shielded areas for radio signals, i.e. boxes made of metals or other material with shielding properties.
- Install the receiver in a dry environment, where no condensation can enter the unit. (The receiver assembly is not waterproof.).
- Mount the receiver using the four holes (please see picture on page 5).
- The receiver must have a separate power supply fitted with a 5 Amp fuse in the positive lead that has either a separate power switch or is shut of by the thrusters system main power switch. The receiver can not be powered by the thrusters/windlass control looms even if you find positive and negative lead there.
- Connect the supplied wiring harnesses to the receiver unit according to the wiring diagram on page 13. Connect thrusters and windlasses to the appropriate connectors according to diagram.
- For use with other windlass brands, connections must be determined by the installer according to output signals diagram on page 14.

NB: **Max. load on the windlass signal output is 4A!**
If the windlass requires more than 4A, use extra control relay.

Note! Faulty installation will render all warranty given by Sleipner Motor AS void.



Mount the receiver by using the 4 holes.

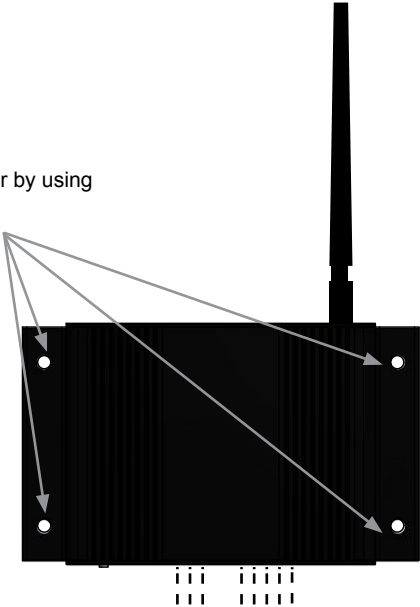

User precautions

- Ensure that you know the location of the main battery switch that disconnects the thruster from all power sources (batteries) so that the thruster/windlass can be turned off in case of a malfunction.
- The maximum continuous usage time of the electrical thruster is approx. 3 minutes. The electric motor has a built-in thermal cut-off switch that will shut it off when overheating and re-engage it when it has cooled down some. This should be considered when planning your maneuvering.
- Never use a thruster close to somebody in the water, as the thruster will draw objects close by into the tunnel and contact with the rotating propellers will cause serious injuries.
- Never use a windlass close to somebody in the water, an unexpected drop of the anchor can cause serious injuries.
- If the thruster stops giving thrust while the electric motor is running, chances are that there is a problem in the drive-system. You must then immediately stop trying to run it, and turn it off, as running the electric motor for more than a few seconds without resistance from the propeller, can cause serious damage to the electric motor.
- When leaving the boat always turn off the main power switch for the thruster/windlass and turn off the power to the receiver.
- We advise to always keep the main engine(s) running while using a thruster/windlass. This will keep the batteries in a good charge condition. This will also give better performance to the thruster.
- It is the owner/captain/other responsible party's full responsibility to assess the risk of any unexpected incidents on the vessel. If the thruster stops giving thrust for some reason while maneuvering you must have considered a plan on how to avoid damage to persons or other objects.

RC-20E

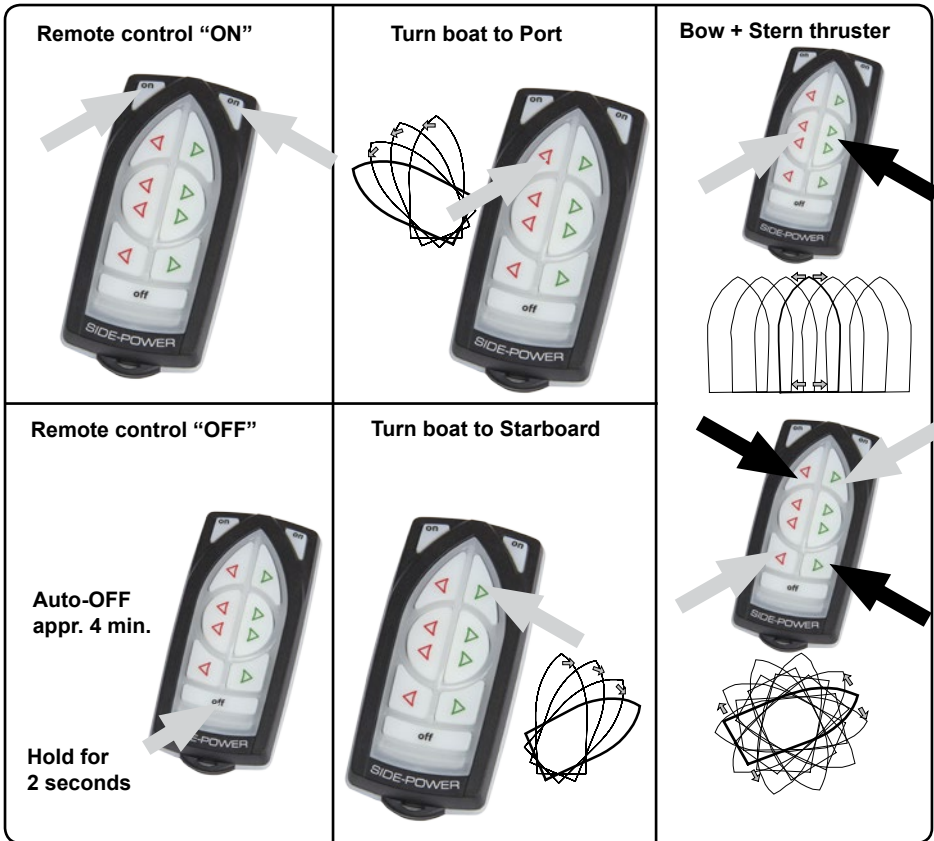

How to use a bow/stern thruster

1. Turn the main power switch for the bow/stern thruster on. Turn on main switch so the receiver has power.
2. Turn on the transmitter by pushing the transmitter's two "ON" buttons. The remote system is now activated and then turns off automatically appr. 4 min. after the last usage.
3. Please take some time to exercise thruster usage in open water to avoid damages to your boat.
4. Turn the bow/stern in the desired direction by pushing the red button for port movement or the green button for starboard movement.

How to use a bow & stern thruster combined

The combination of a bow and stern thruster offers total maneuverability to the boat and the opportunity to move the bow and the stern separately of each other. The remote middle buttons gives you the opportunity to operate both thrusters in the same direction with one keypress, making sideways movement easier.

Remote Control Deactivation

Push the transmitter's "OFF" button for 2 seconds (the remote control deactivates automatically after approx. 4 minutes after the last usage).

- If in doubt, try in open water first!



RC-21E

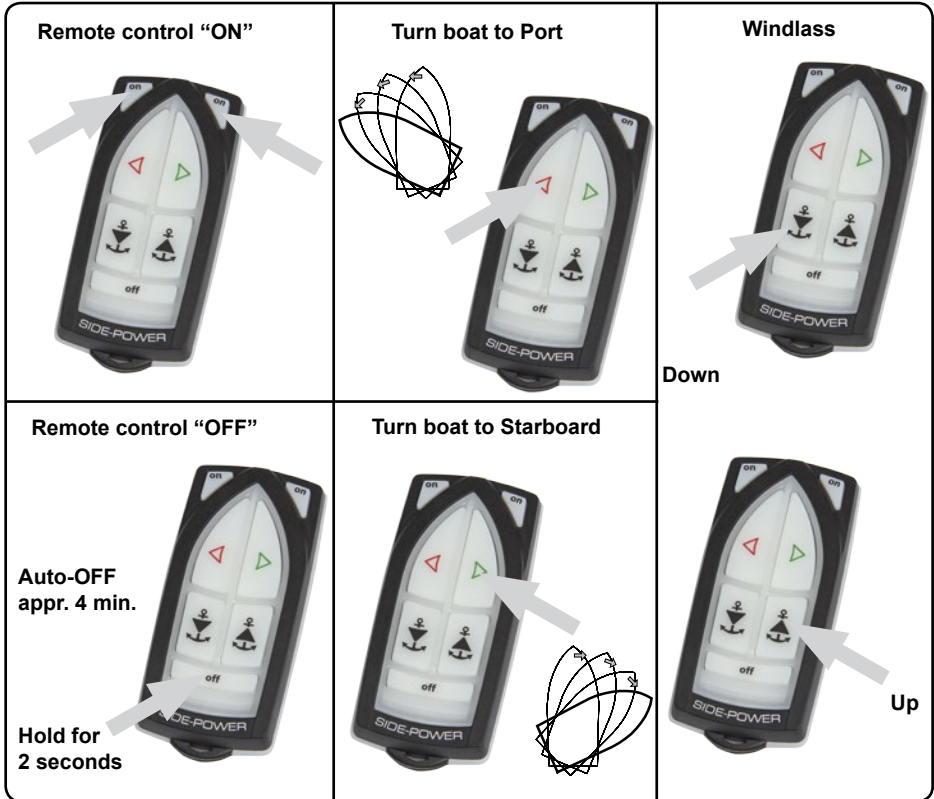

How to use a bow thruster

1. Turn the main power switch for the bow thruster on. Turn on main switch so the receiver has power.
2. Turn on the transmitter by pushing the transmitter's two "ON" buttons. The remote system is now activated and then turns off automatically appr. 4 min. after the last usage.
3. Please take some time to exercise thruster usage in open water to avoid damages to your boat.
4. Turn the bow in the desired direction. By pushing the red button for port movement or the green button for starboard movement.

How to use the windlass

1. Turn the main power switch for the windlass on. Turn on the power to the receiver.
2. Turn on the transmitter by pushing the transmitter's two "ON" buttons. The remote system is now activated and then turns off automatically appr. 4 min. after the last usage.
3. Please consult your windlass manual for use and precautions.

Remote Control Deactivation

Push the transmitter's "OFF" button for two seconds (the remote control deactivates automatically after approx. 4 minutes after the last usage).

- If in doubt, try in open water first!



RC-22E



How to use a bow/stern windlass









1. Turn the main power switch for the windlass on. Turn on main switch so the receiver has power.
2. Turn on the transmitter by pushing the transmitter's two "ON" buttons. The remote system is now activated and then turns off automatically appr. 4 min. after the last usage.
3. Please consult your windlass manual for use and precautions.

Remote Control Deactivation

Push the transmitter's "OFF" button for two seconds (the remote control deactivates automatically after approx. 4 minutes after the last usage).



RC-23E

<p>Remote control "ON"</p> 	<p>Turn boat to Port</p> 	<p>Bow + Stern thruster</p> 
<p>Remote control "OFF"</p> <p>Auto-OFF appr. 4 min.</p>  <p>Hold for 2 seconds</p>	<p>Turn boat to Starboard</p> 	
<p>Windlass 1</p>  <p>Down</p> <p>Up</p>		
<p>Windlass 2</p>  <p>Down</p> <p>Up</p>		



How to use a bow/stern thruster

1. Turn the main power switch for the bow/stern thruster on. Turn on main switch so the receiver has power.
2. Turn on the transmitter by pushing the transmitter's two "ON" buttons. The remote system is now activated and then turns off automatically appr. 4 min. after the last usage.
3. Please take some time to exercise thruster usage in open water to avoid damages to your boat.
4. Turn the bow/stern in the desired direction by pushing the red button for port movement or the green button for starboard movement.

How to use a bow & stern thruster combined

The combination of a bow and stern thruster offers total manouverability to the boat and the opportunity to move the bow and the stern separately of each other. The remote middle buttons gives you the opportunity to operate both thrusters in the same direction with one keypress, making sideways movement easier.

How to use the bow/stern windlass

1. Turn the main power switch for the windlass on. Turn on the power to the receiver.
2. Turn on the transmitter by pushing the transmitter's two "ON" buttons. The remote system is now activated and then turns off automatically appr. 4 min. after the last usage.
3. Please consult your windlass manual for use and precautions.

Remote Control Deactivation

Push the transmitter's "OFF" button for two seconds (the remote control deactivates automatically after approx. 4 minutes after the last usage). Turn off the power switch for the receiver.

- **If in doubt, try in open water first!**



Transmitter LED operation and alarm indication

State	LED status	Alarm status
Transmitter ON	The yellow LED's blink each second	No sound
Buttons activated	The yellow LED's blink fast	No sound
Pairing mode	All LED's on	No sound
Connection lost	Red LED is blinking once each second	3 beeps from the buzzer each second
Low battery	Red LED blink	One beep

Receiver LED indicator

State	LED status
Power on the receiver and no transmitter connected	Green LED is toggling
Power on the receiver and at least one transmitter connected	Green LED lit
No power to the receiver.	Both LED is off
Receiver in pairing mode	Both the red and green LED blinking

Electric diagram

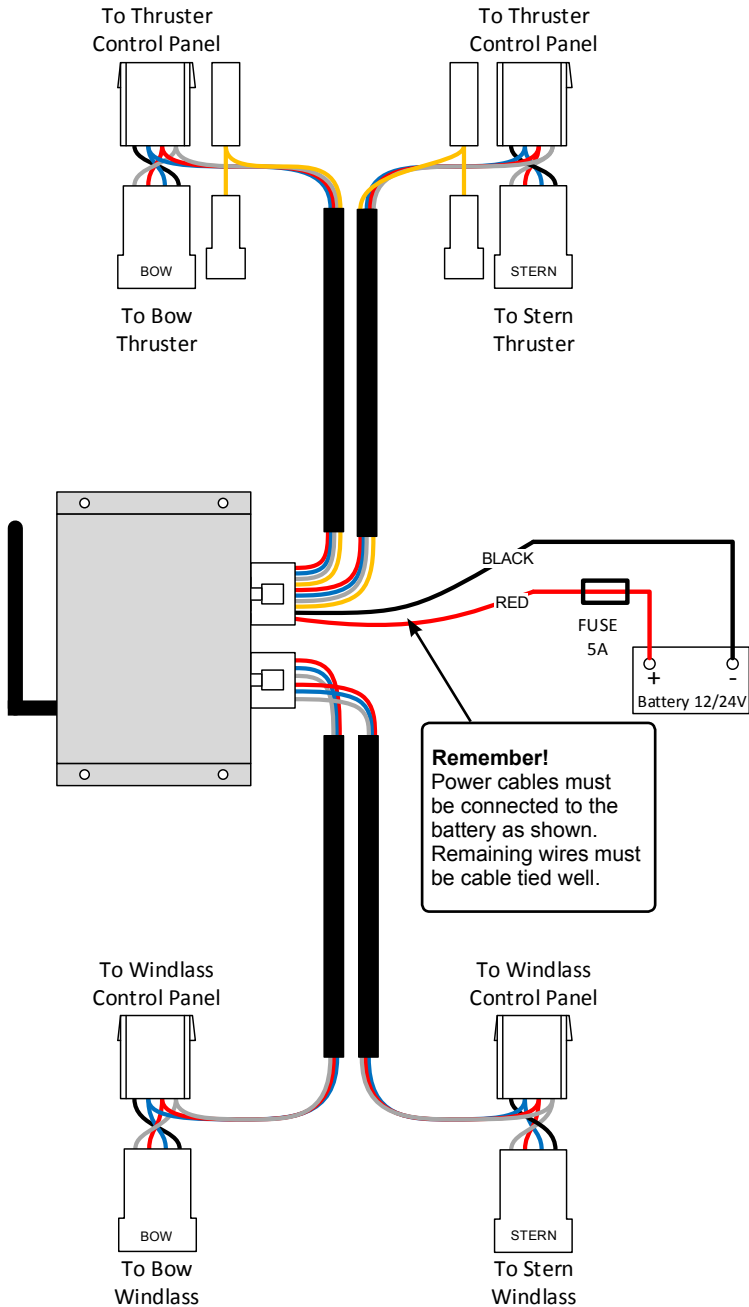

Output signals diagram

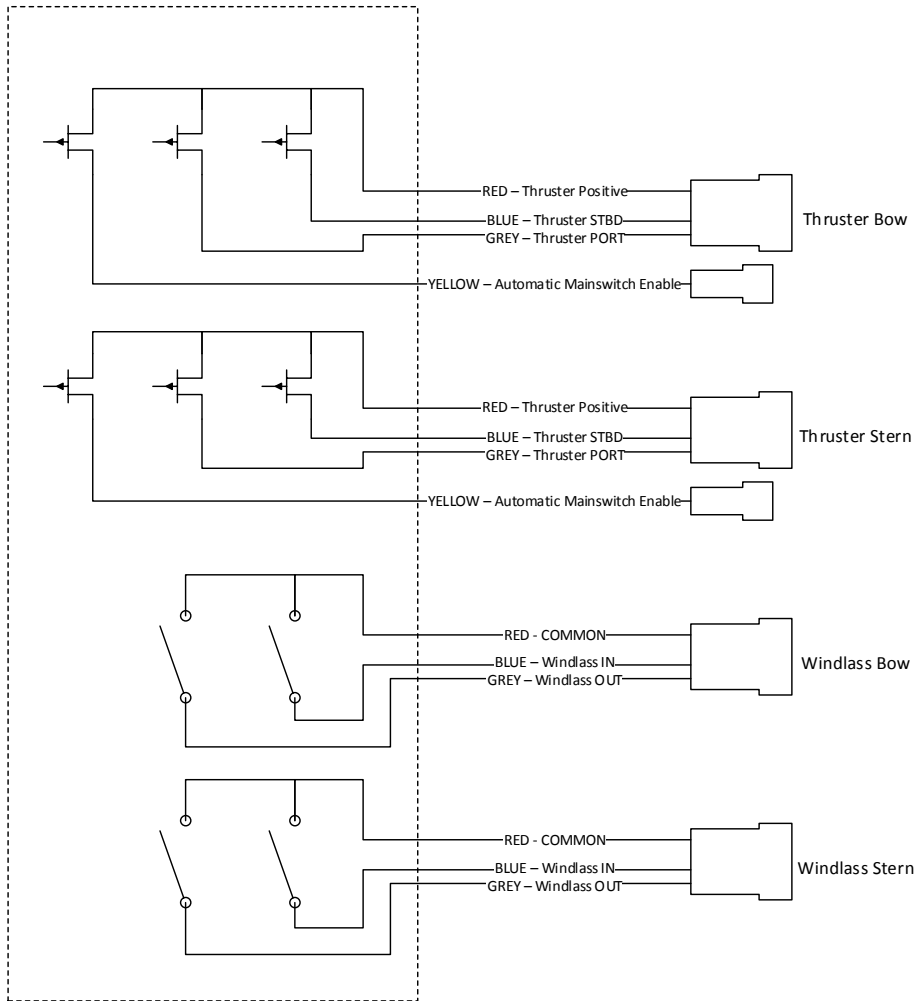

Programming additional receivers



The original transmitter and receiver have the same factory preset code so that no programming is necessary. When additional transmitters are to be used, the additional transmitters has to be paired with the receiver.

1. Be sure that there is power on the receiver (Green status LED blinking) and that the transmitter that should be paired is off.
2. Push the Pair Button on the receiver to put the receiver in pairing mode (as shown above). Both red and green led's should start to blink simultaneously.
3. Within 10s after the receiver pair button is pushed, set the transmitter in pairing mode by holding the off button and pressing both "ON" buttons at the same time, all the transmitter LED's turn on indicating that it is set in pairing mode. When a pairing signal is received from the receiver the transmitter LED's while turn off and the system is ready to be used. If no pairing signal received within 10s the transmitter will leave the pairing mode.
4. Additional transmitters must be programmed according to step 2-3. You can pair up to 4 transmitters.
5. To clear all transmitters paired with the receiver hold the pair button on the receiver for approximately 10s until the red and green led stop blinking. When the LED's stop blinking release the pair button, the green led will again start to blink when the receiver has completed the reset process. The receiver is then ready to pair with up to four transmitters.

Replacing transmitter battery

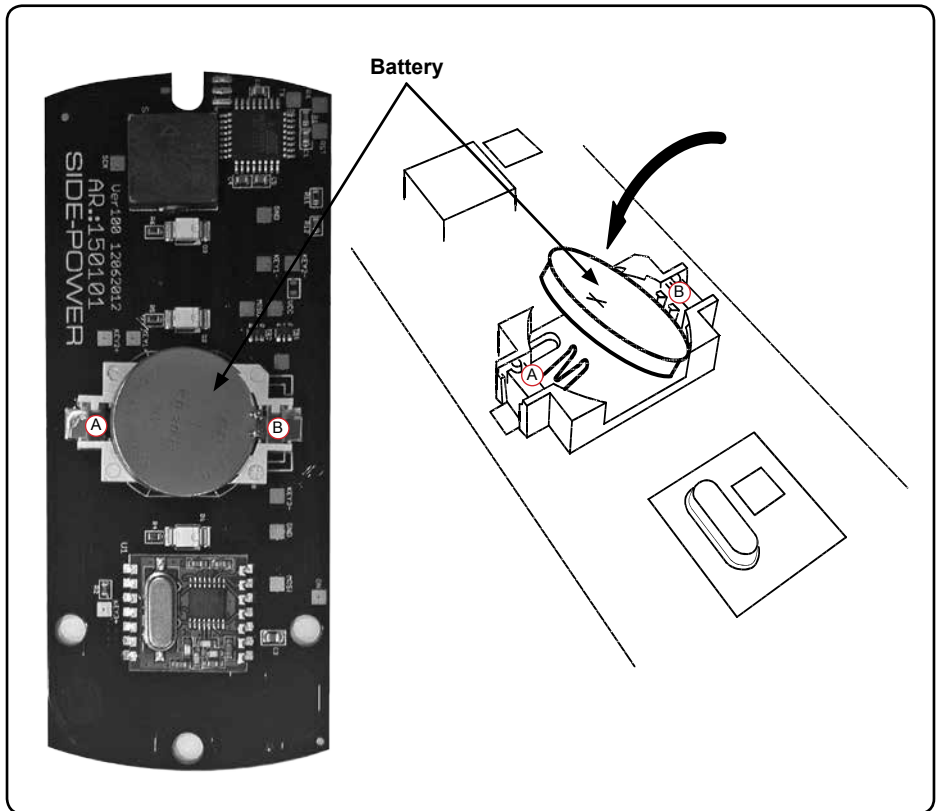

WARNING:

Before working on the transmitter, deactivate the transmitter and the receiver (push "OFF" on the transmitter(s)) and turn off the power to the receiver as well as the thruster mainswitch.

1. Open the transmitter case by removing the 3 torque screws.
2. Remove the battery by inserting a screwdriver or similar between battery and holder at point A, and gently flip the battery out, taking care not damaging the battery grips at point B.
3. Insert the new battery (Type CR2032, 3V - Brand name recommended). Be sure to insert the battery with the positive pole up diagonally into the battery holder, ensuring that the edge of the battery is under the battery grips (B). Press the battery down until secured at point A.
4. Close the transmitter. Put the cover back in place, ensure that the rubber seal between remote upper and lower part is located correctly. Place the 3 screws (remember sealing washer) in their recessed holes and tighten.



Dimensions

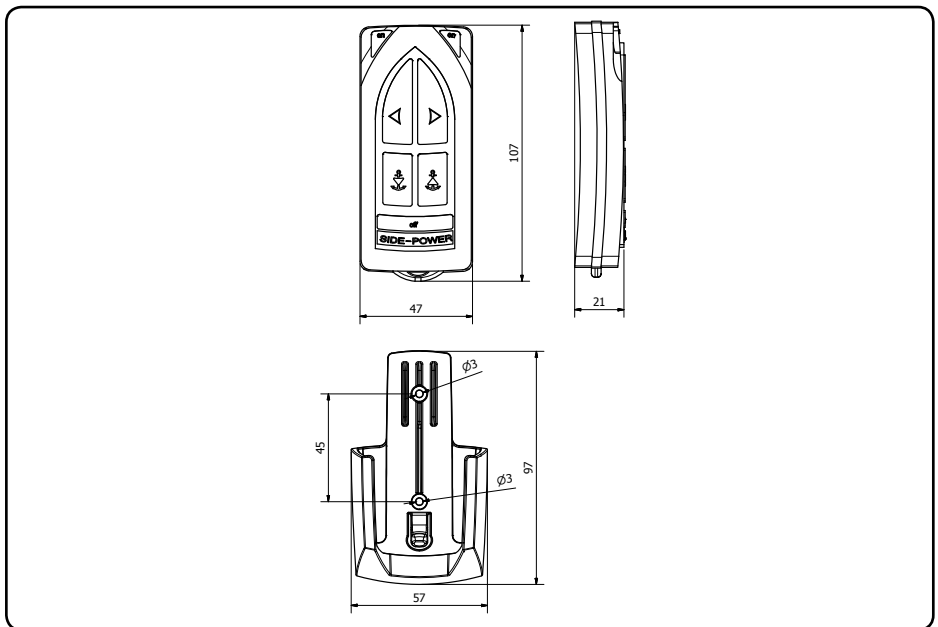
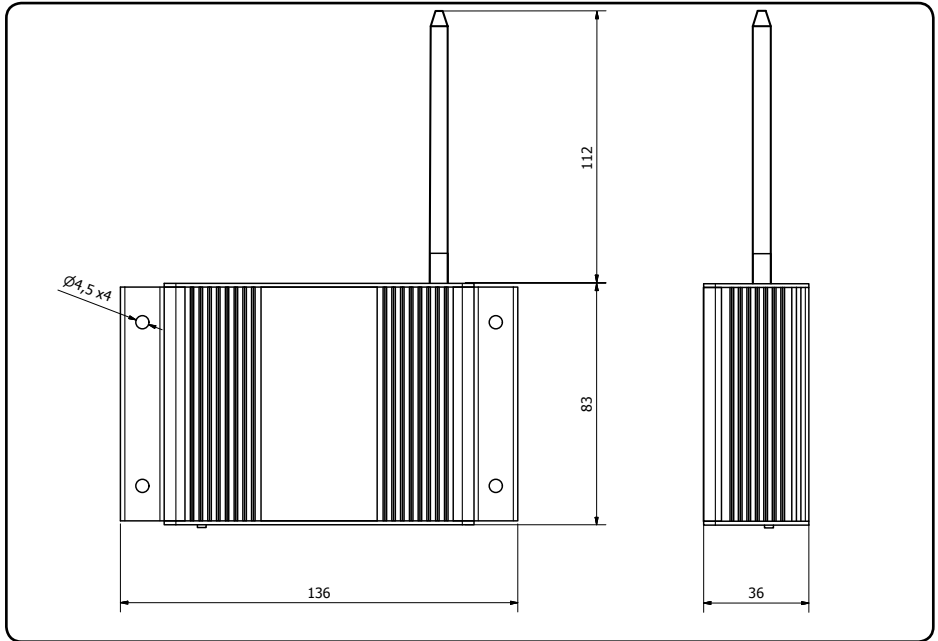





Worldwide sales and service



www.side-power.com



SLEIPNER MOTOR • AS P.O. Box 519 • N-1612 Fredrikstad • Norway
Tel: +47 69 30 00 60 • Fax: +47 69 30 00 70 • www.side-power.com • sidepower@sleipner.no

The information given in the document was correct at the time it was published. However, Sleipner Motor AS can not accept liability for any inaccuracies or omissions it may contain. Continuous product improvement may change the product specifications without notice. Therefore, Sleipner Motor AS can not accept liability for any possible differences between product and document.